

808nm 150W High Power Fiber Coupled Diode Laser STK808DN2RN-150.0W

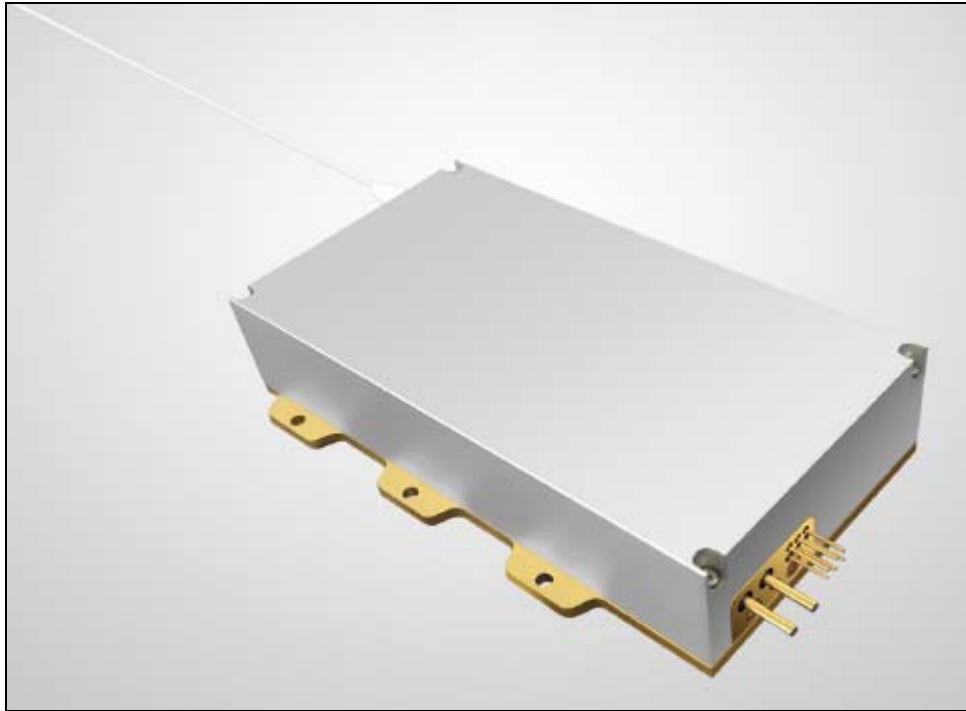

Features:

- 808nm wavelength
- 150W output power
- 400 μ m fiber core diameter
- 0.22N.A.

Applications:

- Solid-state laser pumping
- Medical use
- Material processing

Our High Power Diode Laser Modules are manufactured by adopting specialized fiber-coupling techniques, resulting in volume products with a high efficiency, stability and superior beam quality. The products are achieved by transforming the asymmetric radiation from the laser diode chip into an output fiber with small core diameter by using special micro optics. Inspecting and burn-in procedures in every aspect come to a result to guarantee each product with the reliability, stability and long lifetime.

Our research staffs are constantly improving and innovating the processing technology in the producing process, based on the professional knowledge and experience accumulated in long-terms. We are also continuously developing new products to meet customers' specific needs.

To provide high quality products with reasonable price is our always goal.

Specifications(25°C)		Symbol	Unit	STK808DN2RN-150.0W		
				Minimum	Typical	Maximum
Parameter ⁽¹⁾	CW Output Power	P _o	W	150	-	-
	Threshold current	I _{th}	A	-	1.8	-
	Operating current	I _{op}	A	-	-	11
	Operating voltage	V _{op}	V	-	-	40
	Reverse Voltage	V _{re}	V	-	50	-
	Slope Efficiency	η	W/A	-	20	-
	Electrical-to-Optical Efficiency	PE	%	-	42	-
	Center wavelength	λ _c	nm	805	-	811
	Spectral width(FWHM)	Δλ	nm	-	5	-
	Back reflection wavelength Range	λ	nm	1040	-	1200
	Back reflection isolation	-	dB	-	30	-
	Wavelength Shift with Temperature	-	nm/°C	-	0.3	-
	Wavelength Shift with Current	-	nm/A	-	1	-
Fiber Data	Buffer diameter	D _{buf}	μm	-	730	-
	Cladding diameter	D _{clad}	μm	-	440	-
	Core diameter	D _{core}	μm	-	400	-
	Numeric aperture	NA	NA	-	0.22	-
	Fiber length ⁽²⁾	l _c	m	1.9	2	2.1
	Connector ⁽³⁾	-	-	-	-	-
	Fiber jacket ⁽⁴⁾	-	-	-	1.5mmPVC	-
	Fiber Bend Radius	-	mm	-	140	-
Thermistor	-	R _t	(K Ω)/β(25°C)	-	10±3%/3477	-
Others	ESD	-	V	-	-	500
	Storage temperature	-	°C	-20	-	70
	Lead Soldering Temp	T _{is}	°C	-	-	260
	Lead Soldering Time	T _{is}	sec	-	-	10
	Operating case temperature ⁽⁵⁾	T _{op}	°C	15	-	35
	Relative Humidity ⁽⁶⁾	-	%	15	-	75

(1) Data measured under operation output at 150W@25°C。

(2) Other length available upon request.

(3) Other connector available upon request.

(4) Other fiber jacket available upon request.

(5) Operating temperature defined by the package case. Acceptable operating range is 15 - 35C, but performance may vary.

(6) A non-condensing environment is required for operation and storage conditions are from -20 to +70 °C with relative humidity between 15 to 75 %.

OPERATING NOTES

- Avoid eye and skin exposure to direct radiation during operation.
- ESD precautions must be taken during storage, transportation and operation.
- Short-circuit is required between pins during storage and transportation.
- Please connect pins to wires by solder instead of using socket when operation current is higher than 6A. Soldering point should be close to the root of the pins. Soldering temperature should be lower than 260°C and time shorter than 10 second.
- Make sure the fiber output end is properly cleaned before operation of laser. Follow safety protocols to avoid injury when handling and cutting the fiber.
- Use constant current power supply to avoid surge current during operation.
- Laser diode must be used according to the specifications.
- Laser diode must work with good cooling.
- Operation temperature ranges from 15°C to 35°C.

- Storage temperature ranges from -20°C to +70°C.

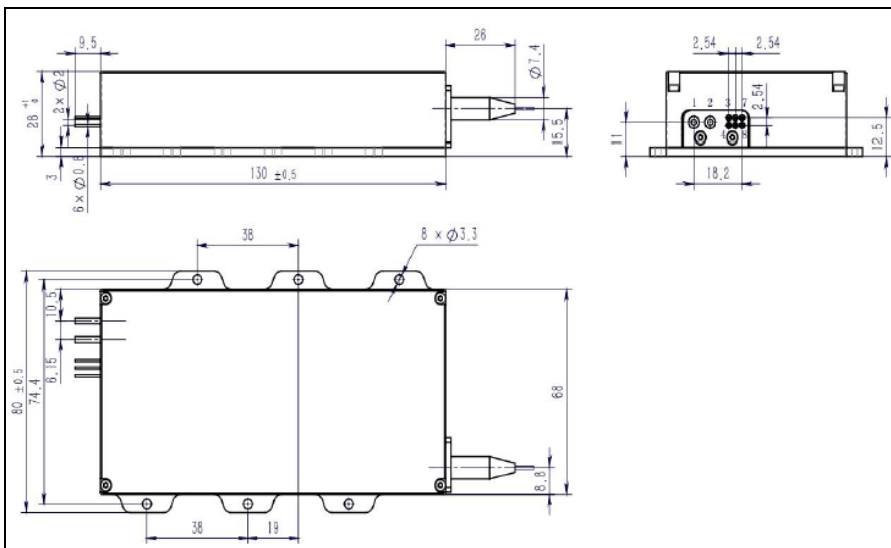
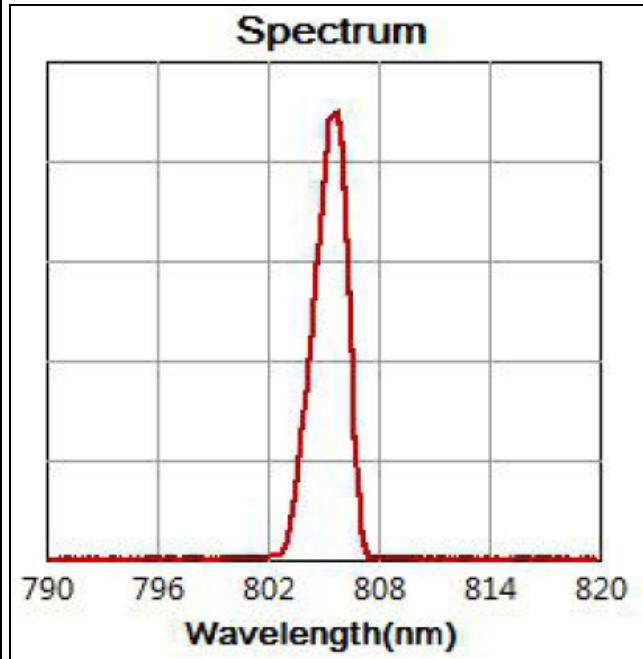
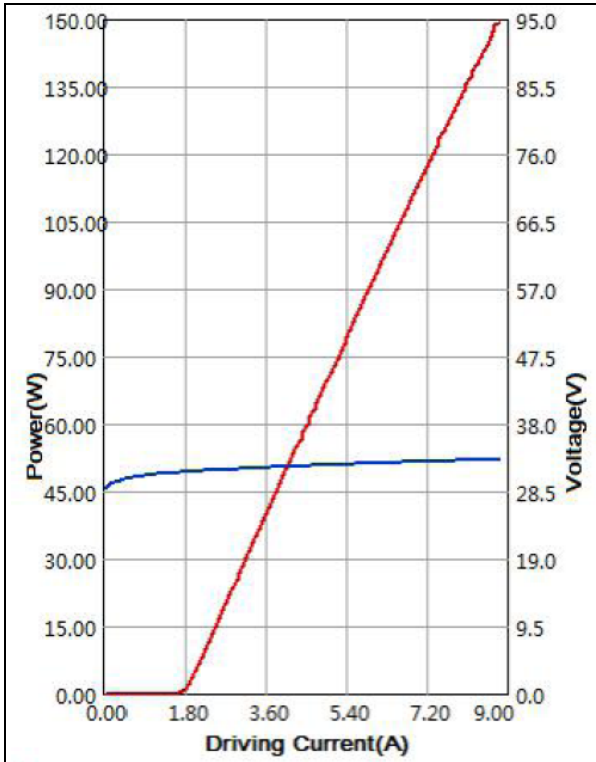

Pins	Function
1	LD (+)
2	LD (-)
3	-
4	-
5	-
6	-
7	-
8	-